

© 1965 BY AMP INCORPORATED. ALL RIGHTS RESERVED. AMP PRODUCTS COVERED BY PATENTS AND/OR PATENTS PENDING. APPROVED PER GOVT CONTRACT NO.

REVISIONS				
ZONE	LTR	DESCRIPTION	DATE	APPROVED
A		REVISED	W-777	10-14-5 m.s./D.H.
B		REVISED	Y-68	1-19-66 m.s. J.H.
C		ADDED -3 PER ECN A-491	4-9-70	PA/AS
D		REV. PER ECN D-644	2/10/75	
E		REV. / ECN H-220	8-14-80	AE
F		REV PER ELD-05-001412	AA 05/05	DE
G		REV PER ECO-05-005359	11/05	PY/DE

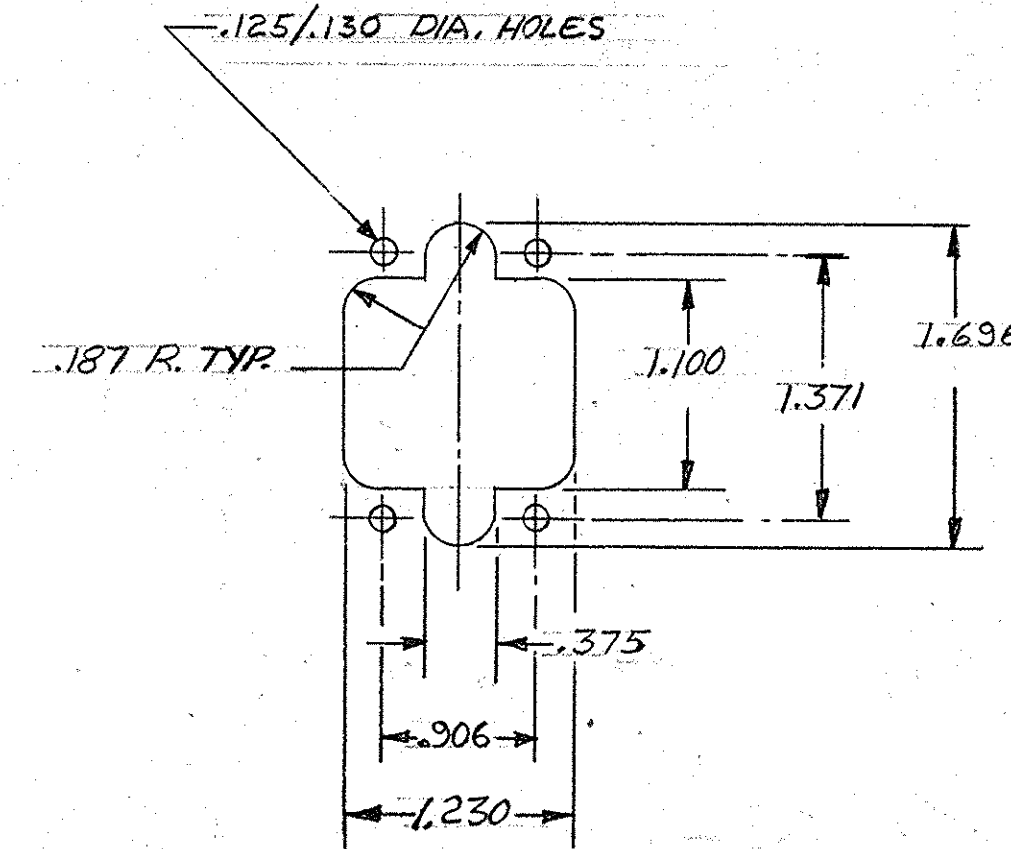

202786-1 FOR SOCKETS  
-3 FOR SOCKETS

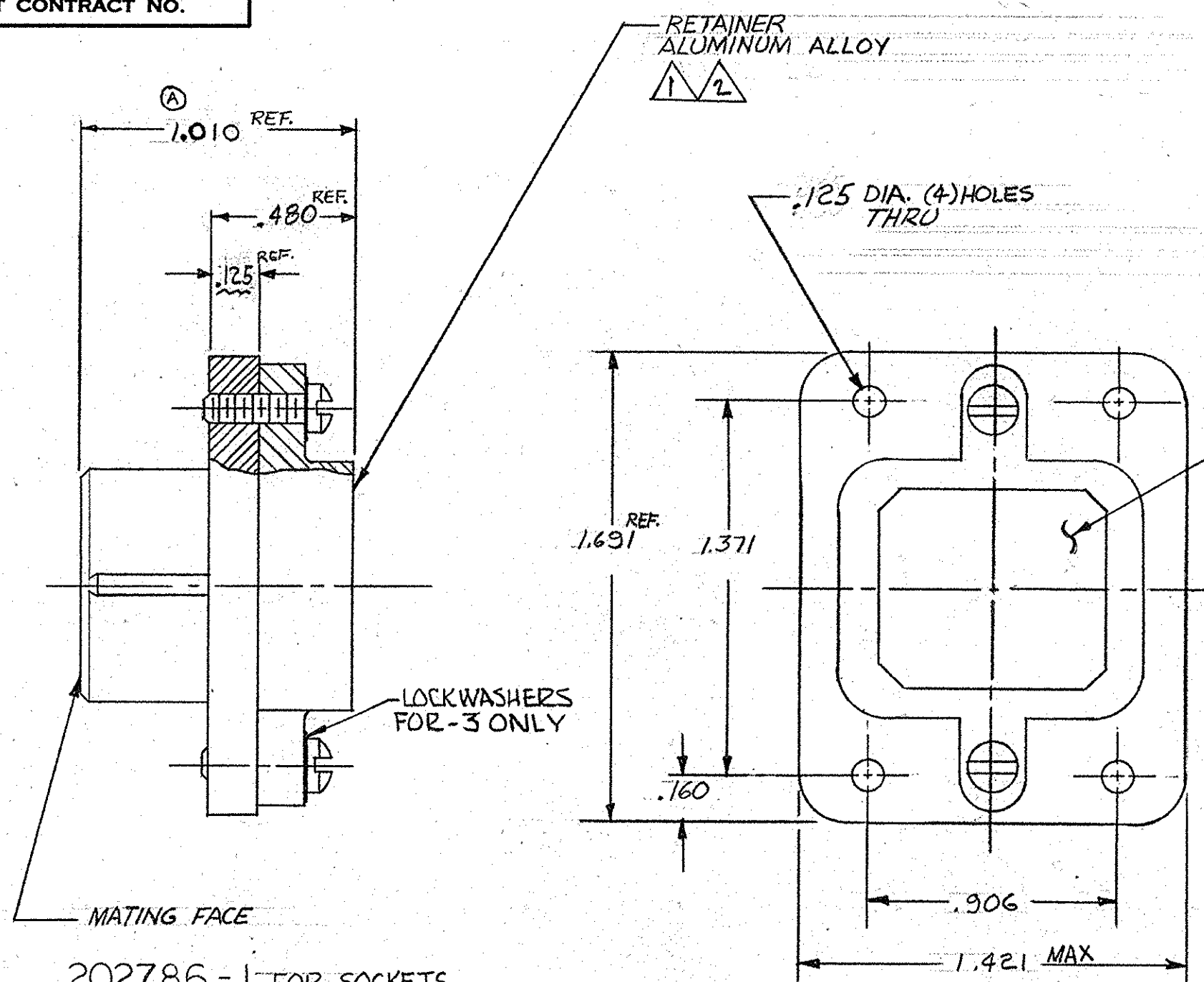
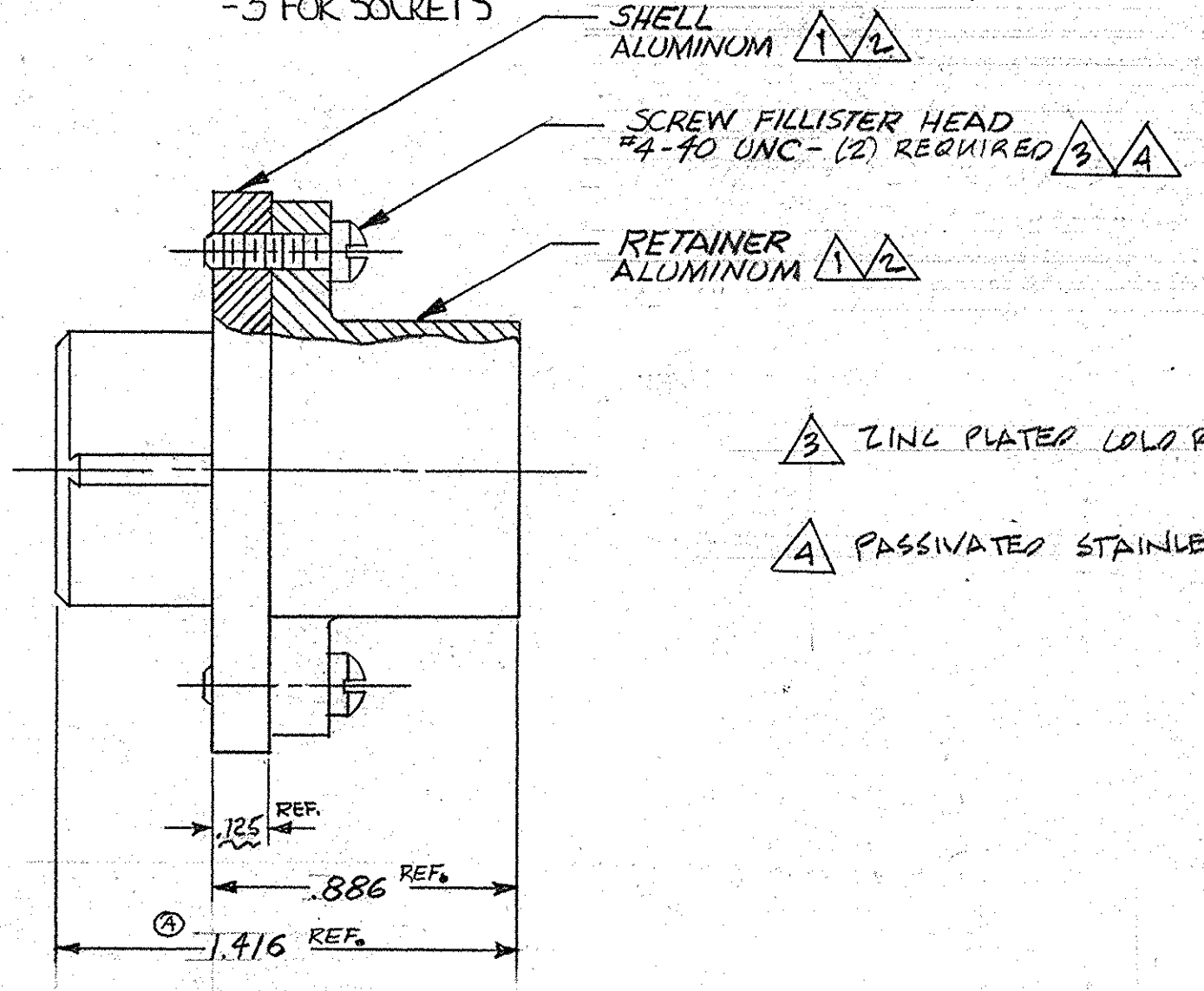

202786-2 FOR PINS

SHELL ALUMINUM 1 2  
SCREW FILLISTER HEAD #4-40 UNC - (2) REQUIRED 3 4  
RETAINER ALUMINUM 1 2

3 ZINC PLATED COLD ROLLED STEEL.  
4 PASSIVATED STAINLESS STEEL.

1 ZINC PLATE PER ASTM-B-1633 TYPE II, CLASS 3 COLORLESS SUPPLEMENTARY CHROMATE.  
2 ELECTROLESS NICKEL PLATE PER SAE-AMS-C-26074 .000400 - .000800 THK (NO INTENTIONAL ADDITIONS OF LEAD OR CHROMIUM PER DFE STD 230-700).

2 4	5-202786-2
2 4	5-202786-1
1 3	202786-3
1 3	202786-2
1 3	202786-1

SUPERSEDED BY 5--2  
SUPERSEDED BY 5--1

AMP INFO	QTY REQD	NOMENCLATURE OR DESCRIPTION	PART OR IDENTIFYING NO
LOC R 39/G			
LIST OF MATERIALS OR PARTS LIST			
UNLESS OTHERWISE SPECIFIED DIMENSIONS ARE IN INCHES TOLERANCES ON		CONTRACT NO	
FRACTIONS ± .11	DECIMALS ± .005	ANGLES ± .11	DR E. Reminger DATE 7/8/65
MATERIAL		CHK R. J. Miller DATE 8/23/65	NAME
HEAT TREAT		DSGN ENGR J. J. Williams DATE 8-24-64	AMP INCORPORATED HARRISBURG, PENNSYLVANIA
FINISH		APPR R. J. Miller DATE 8/26/65	PLUG ASSEMBLY MODULE SERIES "G" (1 BLOCK)
		DSGN APPD	SIZE C
		OTHER APPD	CODE IDENT NO 00779
			NUMBER 202786
		SCALE 2-1	WT CALC ACTUAL SHEET